

Guinness

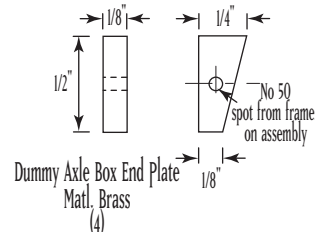
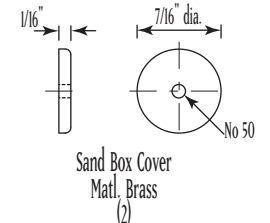
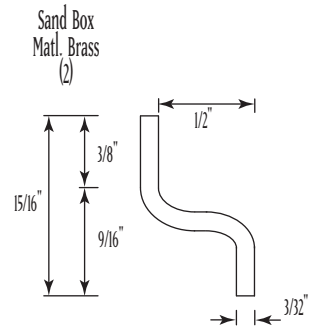
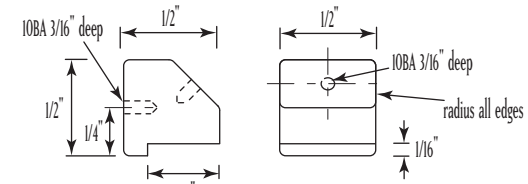
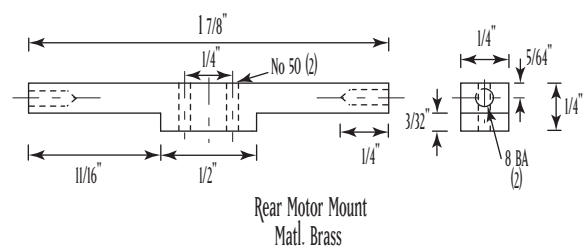
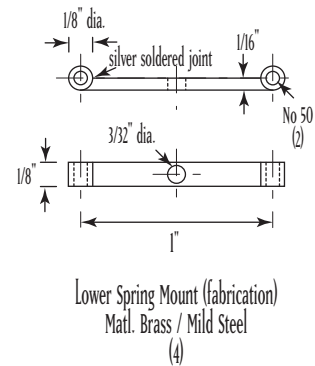
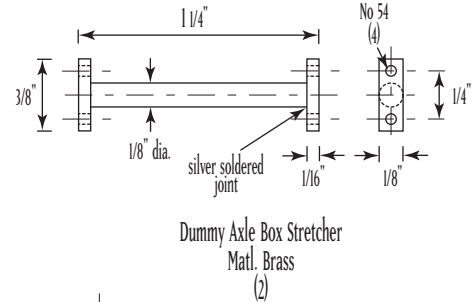
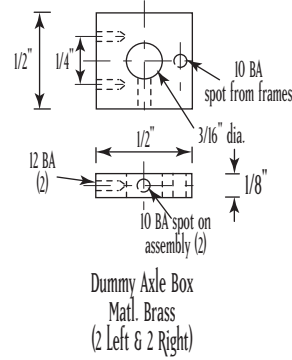
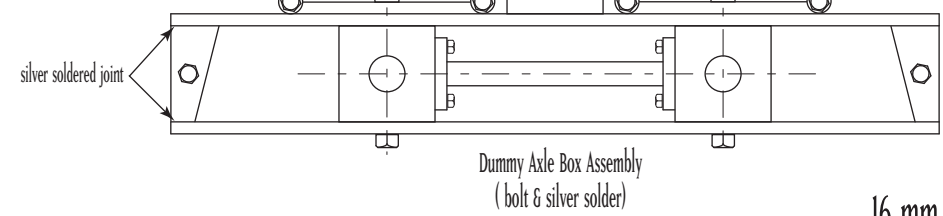
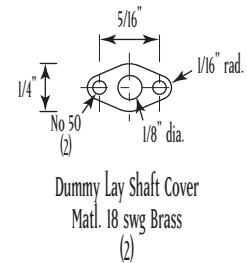
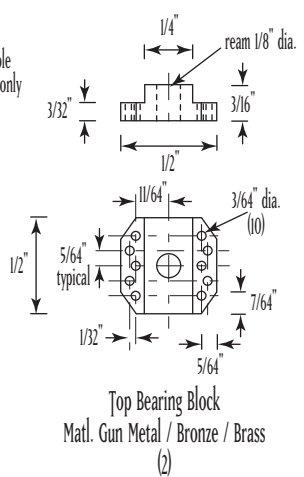

16 mm to 1 foot scale

Title:	Frame Fittings
Date:	05/05/2009
Tolerance:	+ 0.005" Unless Stated Otherwise - 0.005"
Material:	As Stated
Drawn By:	Robert John Bath