

Frames, 1.2mm or 1.5mm mild steel.  
 All holes 1.8mm to clear 10BA unless otherwise indicated.

Dashed line shows position of  
 40mm length of 12 x 8 angle to support lubricator

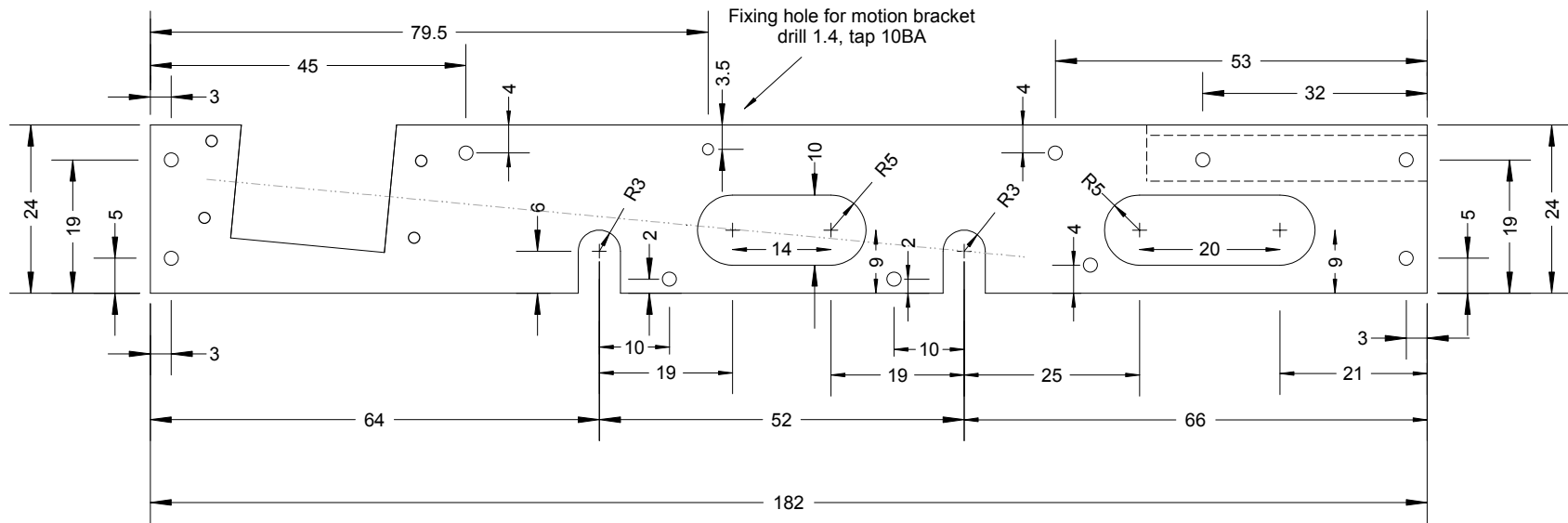

Cutout for cylinders and valve chests  
 Scale twice full size

Fixing holes for cylinders, locate  
 from port block, drill 1.4mm, tap 10BA

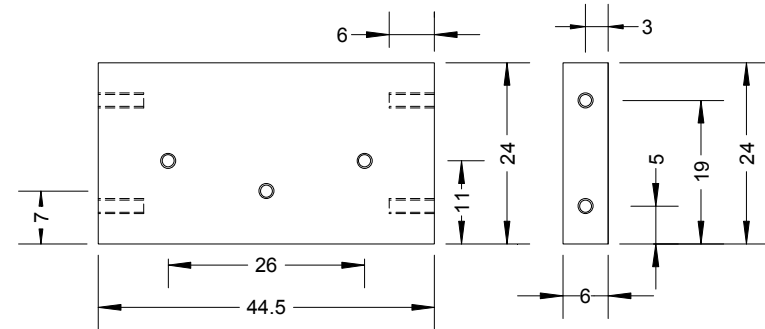
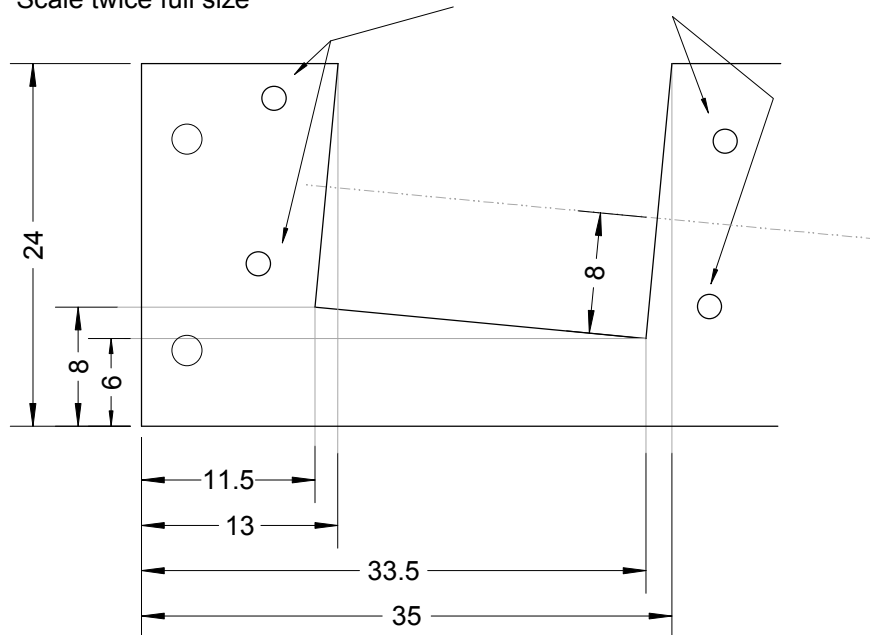

Frame spacers, 2 off, mild steel or brass  
 drill all holes, 1.4mm and tap 10BA

Note: holes shown in face are to secure buffer beams and coupling  
 The builder may want to choose alternatives.

Wild Rose III  
 sheet 5  
 Frames